

Product Specifications

12-Port 10/100TX 802.3at PoE + 4-Port 10/100TX 802.3bt PoE + 2-Port Gigabit TP + 2-Port SFP
Ethernet Switch with LCD Management

FGSW-2022VHP

Version 1.1

This document contains confidential proprietary information and is property of PLANET. The contents of this document should not be disclosed to unauthorized persons without the written consent of PLANET.

Change History:

Revision:	Date:	Author:	Change List
Version 1.0	2019/09/12	Keithy Lin	Initial Release
Version 1.1	2019/10/04	Keithy Lin	Modify the SFP slots information

Author:	Keithy Lin	Editor:	Mark Kao
Reviewed By:	Jonas Yang	Approved By:	Kent Kang

1. PRODUCT DESCRIPTION



Just “Plug and Watch” for a Quick Solution

PLANET FGSW-2022VHP is an ideal “Plug and Watch” Power over Ethernet solution which provides quick installation, real-time PoE work status monitoring and immediate troubleshooting through its unique LCD display to improve work efficiency and quality without any PC or software required.

The FGSW-2022VHP is equipped with 12 10/100BASE-TX ports featuring 802.3at Power over Ethernet Plus (PoE+) copper interfaces and **4 10/100BASE-TX ports featuring 802.3bt PoE++** copper interfaces. With a total PoE power budget of up to 300 watts and non-blocking data switching performance, the FGSW-2022VHP fulfills the demand of sufficient PoE power for HD IP surveillance. It offers a desktop-sized, reliable and visible power solution for small businesses and system integrators deploying Power over Ethernet networks.

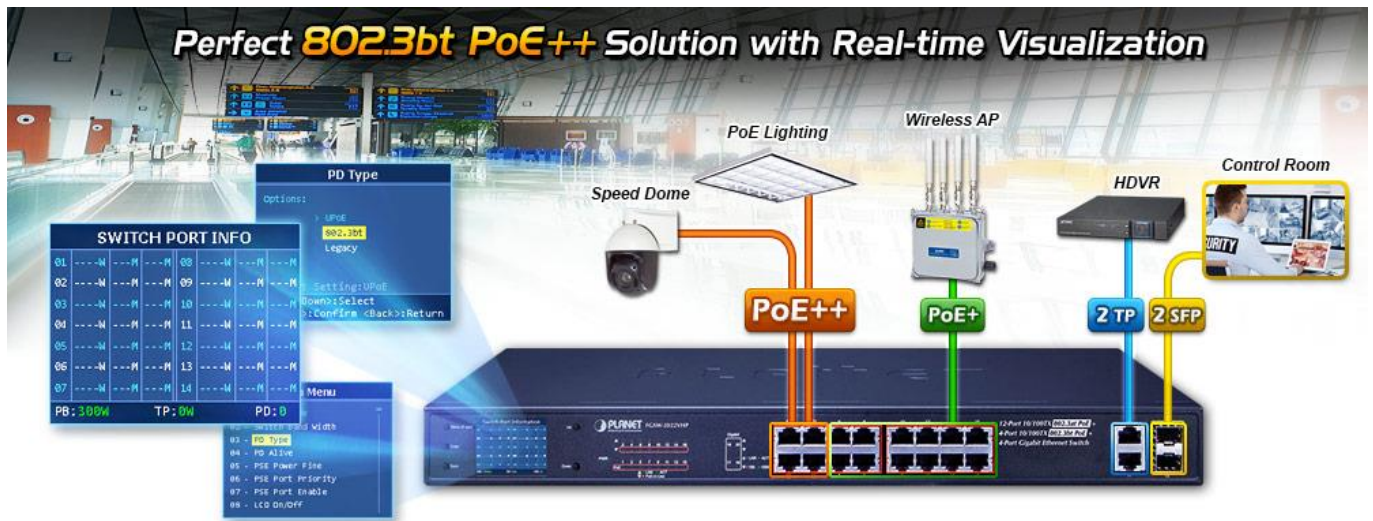

Smart and Intuitive LCD Control

The FGSW-2022VHP provides an intuitive color panel on its front panel that facilitates the Ethernet management and PoE PD management. It greatly promotes management efficiency in large-scale networks designed for enterprises, hotels, shopping malls, government buildings and other public areas, and features the following special management and status functions:

- PoE management and status
- Port management and status
- Switch mode includes Standard, VLAN or Extend
- PD type: 802.3bt, UPoE, Legacy

- Budget and bandwidth control
- PD alive check
- Screen saver, fan control and factory default
- Security password

Switch Port Information													
01	---	W	---	M	---	M	06	---	W	---	M	---	M
02	---	W	---	M	---	M	07	---	W	---	M	---	M
03	---	W	---	M	---	M	08	---	W	---	M	---	M
04	---	W	---	M	---	M	09	---	W	---	M	---	M
05	---	W	---	M	---	M	10	---	W	---	M	---	M
PB:300W			TP:0W			PD:0							

Main Menu	
01	Switch Mode
02	Budget Control
03	PSE Port Priority
04	PSE Port Enable
05	PD Type
06	Alive Check
07	Bandwidth
08	Fan Control

Switch Mode	
Options:	
>	Standard
	VLAN
	Extend
Current Setting: Standard	
<UP>/<Down>:Select	
<Enter>:Confirm <Back>:Return	

PSE Port Priority	
Port	Priority
01	Critical
	High
	> Low
Current Setting: LOW	
<UP>/<Down>:Select	
<Enter>:Confirm <Back>:Return	



Standard, VLAN or Extend Operation Mode

The FGSW-2022VHP provides Standard, VLAN or Extend operation mode. The FGSW-2022VHP operates as a normal IEEE 802.3at/bt PoE switch in the Standard operation mode.

Standard Mode (default)

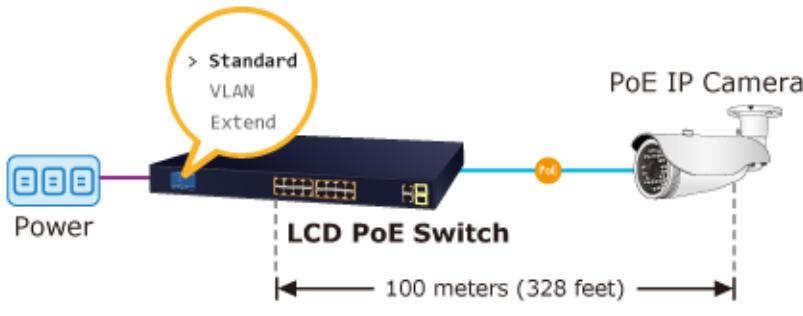

—●— 100BASE-TX UTP with PoE

The VLAN operation mode features the port-based VLAN function that can help to prevent the IP camera's multicast or broadcast storm from influencing each other.

VLAN Isolation Mode

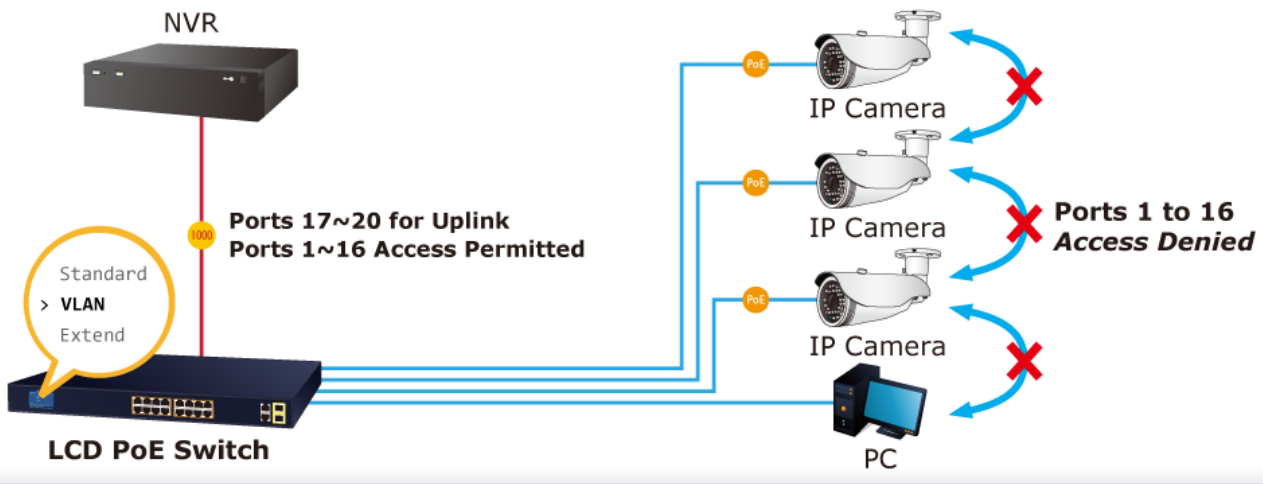

—●— 1000BASE-SX/LX Fiber Optic
—●— 100BASE-TX UTP
—●— 100BASE-TX UTP with PoE

In the Extend operation mode, the FGSW-2022VHP operates on a per-port basis at 10Mbps duplex operation but can provide PoE power output over a distance of up to 250 meters overcoming the 100m limit on Ethernet UTP cable. With this brand-new feature, the FGSW-2022VHP provides an additional solution for 802.3at/bt PoE distance extension, thus saving the cost of Ethernet cable installation. Its VLAN isolation function isolates ports so as to prevent broadcast storm and defend DHCP spoofing in the Extend operation mode.

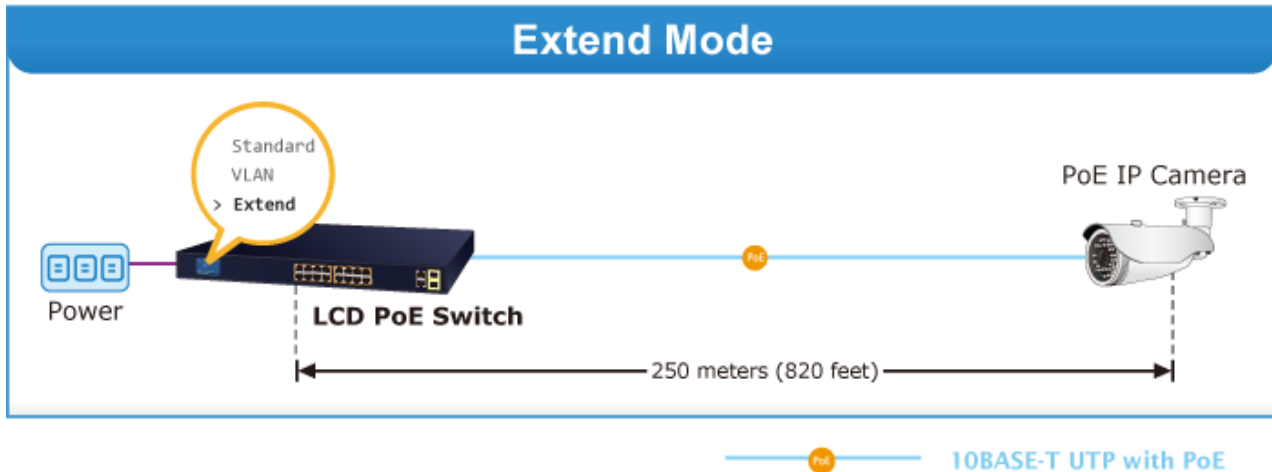

Flexible Extension Solution

The two mini-GBIC slots built in the FGSW-2022VHP are compatible with the 1000BASE-X SFP (small form-factor pluggable) fiber transceiver, uplinked to the backbone switch and monitoring center in long distance. The distance can be extended from 550 meters (multi-mode fiber) to 10/20/40/80/120 kilometers (single-mode fiber or WDM fiber). They are well suited for applications within the enterprise data centers and distributions.

Robust Protection

The FGSW-2022VHP provides contact discharge of $\pm 6\text{KV}$ DC and air discharge of $\pm 8\text{KV}$ DC for Ethernet ESD protection. It also supports $\pm 6\text{KV}$ surge immunity to improve product stability and protects users' networks from devastating ESD attacks, making sure the flow of operation does not fluctuate.

Easy Installation and Cable Connection

As data and power are transmitted over one cable, the FGSW-2022VHP does not need a second cable and electrical outlets on the wall, ceiling or any unreachable place. Thus, it helps to lower the installation costs and simplify the installation effort. All the RJ45 copper interfaces of the FGSW-2022VHP support 10/100Mbps auto-negotiation for optimal speed detection through RJ45 Cat. 5e/6 cable. It also supports standard auto-MDI/MDI-X that can detect the type of connection to any Ethernet device without requiring special straight-through or crossover cables.

2. PRODUCT FEATURES

➤ Physical Port

- 16-port 10/100BASE-TX Fast Ethernet RJ45 copper
- 2 10/100/1000BASE-T Gigabit RJ45 copper
- 2 1000BASE-X SFP interfaces

➤ Power over Ethernet

- Complies with IEEE 802.3at/bt Power over Ethernet PSE
- Selectable PoE mode: IEEE 802.3bt/UPoE/Legacy
- Ports 1 to 4 support up to 60 watts; ports 5 to 16 support up to 32 watts
- Each port supports 54V DC power to PoE powered device
- 300-watt PoE budget
- Auto detects powered device (PD)
- Circuit protection prevents power interference between ports
- Remote power feeding up to 100m in standard mode and 250m in extend mode

➤ Smart LCD

- The LCD switch features “Standard”, “VLAN” or “Extend” mode selection; the “Extend” mode features about 45-/20-watt PoE transmission distance of 250m at speed of 10Mbps and VLAN isolation
- The LCD switch is able to isolate ports to prevent broadcast storm and defend DHCP spoofing
- Power low-voltage, power over-voltage and PSE over-temperature protection
- Security password, screen saver, fan control, factory default and save configuration
- PoE management
 - Total PoE power budget control
 - Per port PoE function enable/disable
 - PoE port power feeding priority
 - Per PoE port power limitation
 - PD alive check

➤ Switching

- Hardware-based 10/100/1000Mbps auto-negotiation and auto MDI/MDI-X
- Flow control for full duplex operation and back pressure for half duplex operation
- 9K Frame size
- Integrates address look-up engine, supporting 8K absolute MAC addresses
- Automatic address learning and address aging

➤ Hardware

- 19-inch desktop size, 1U height, rack mountable
- 2-inch color LCD with smart management functions
- LED indicators for system power, per port PoE ready and PoE activity, speed, Link/Act
- 3 silent fans to provide stable and efficient power performance

- Supports contact discharge of $\pm 6\text{KV}$ DC and air discharge of $\pm 8\text{KV}$ DC for Ethernet ESD protection
- Supports $\pm 6\text{KV}$ surge immunity

3. PRODUCT SPECIFICATIONS

3.1 Main Components

Switch ASIC	RTL8332L	x 1
Fast Ethernet PHY	RTL8208L	x 2
Gigabit PHY	RTL8214B	x 1
PoE Controller	PD69200	x 1
PoE PSE	PD69208M	x 3
Power Supply	330W	x 1

3.2 Function Specifications

Model	FGSW-2022VHP
Hardware Specifications	
Copper Ports	16 10/100BASE-TX RJ45 auto-MDI/MDI-X ports with port-1 to port-16 2 10/100/1000BASE-T RJ45 auto-MDI/MDI-X ports with port-17 to port-18
SFP/mini-GBIC Slots	2 1000BASE-X SFP interfaces with port-19 to port-20
PoE Injector Ports	4 ports with 802.3bt PoE++ injector function with port-1 to port-4 12 ports with 802.3at PoE+ injector function with port-5 to port-16
Switch Architecture	Store-and-Forward
Switch Fabric	11.2Gbps/non-blocking
Throughput (packet per second)	8.3Mpps@64 bytes packet
MAC Address Table	8K entries
Jumbo Frame	9K bytes
Flow Control	IEEE 802.3x pause frame for full duplex; back pressure for half duplex
LED Indicators	<p>System: Power (Green)</p> <p>10/100BASE-TX RJ45 Interfaces: 10/100Mbps LNK/ACT (Green) PoE-in-Use (Amber)</p> <p>1000BASE-X SFP Interfaces: LNK/ACT (Green) 1000Mbps (Green)</p> <p>10/100/1000BASE-T TP Interfaces LNK/ACT (Green) 100Mbps (Red) 1000Mbps (Green)</p>
LCD Monitor (W x D)	40.6 x 30.5 mm, 2-inch
Buttons	Menu, Enter, Back, Up and Down

Dimensions (W x D x H)	233 x 440 x 44 mm (1U height)
Enclosure	Metal
Weight	3.3kg
Power Requirements	100~240V AC, 50/60Hz, 5A max.
Power Consumption/ Dissipation	Max. 330watts/1132 BTU
Thermal Fan	3
ESD Protection	Contact discharge of ±6KV DC Air discharge of ±8KV DC
Surge Protection	±6KV
Power over Ethernet	
PoE Standard	IEEE 802.3bt PoE++ Type-3 PSE (Port 1-4) IEEE 802.3af/at PoE+ PSE (Port 5-16)
PoE Power Supply Type	802.3bt/UPoE/Legacy (Port 1-4) End-span (Port 5-16)
PoE Power Output	Per PoE++ port 54V DC, 1.2A. max. 60 watts Per PoE+ port 54V DC, 600mA. max. 32 watts
Power Pin Assignment	802.3bt: 1/2 (+), 3/6 (-), 4/5 (+), 7/8 (-) End-span: 1/2 (+), 3/6 (-)
PoE Power Budget	300 watts
Max. Number of Class 2 PDs	16
Max. Number of Class 3 PDs	16
Max. Number of Class 4 PDs	11
Max. Number of Class 5 PDs	4
Max. Number of Class 6 PDs	4
Standards Conformance	
Regulatory Compliance	FCC Part 15 Class A, CE
Standards Compliance	IEEE 802.3 10BASE-T IEEE 802.3u 100BASE-TX IEEE 802.3ab Gigabit 1000BASE-T IEEE 802.3z Gigabit SX/LX IEEE 802.3x Flow Control and Back Pressure IEEE 802.3af Power over Ethernet IEEE 802.3at Power over Ethernet Plus IEEE 802.3bt PoE++ (Type 3)
Environment	
Operating	Temperature: -10 ~ 60 degrees C Relative Humidity: 5 ~ 90% (non-condensing)
Storage	Temperature: -15 ~ 70 degrees C Relative Humidity: 5 ~ 90% (non-condensing)

3.3 Physical Specifications:

■ **Dimensions (W x D x H)**

233 x 440 x 44 mm

■ **Weight**

3.3kg

■ **Diagram**

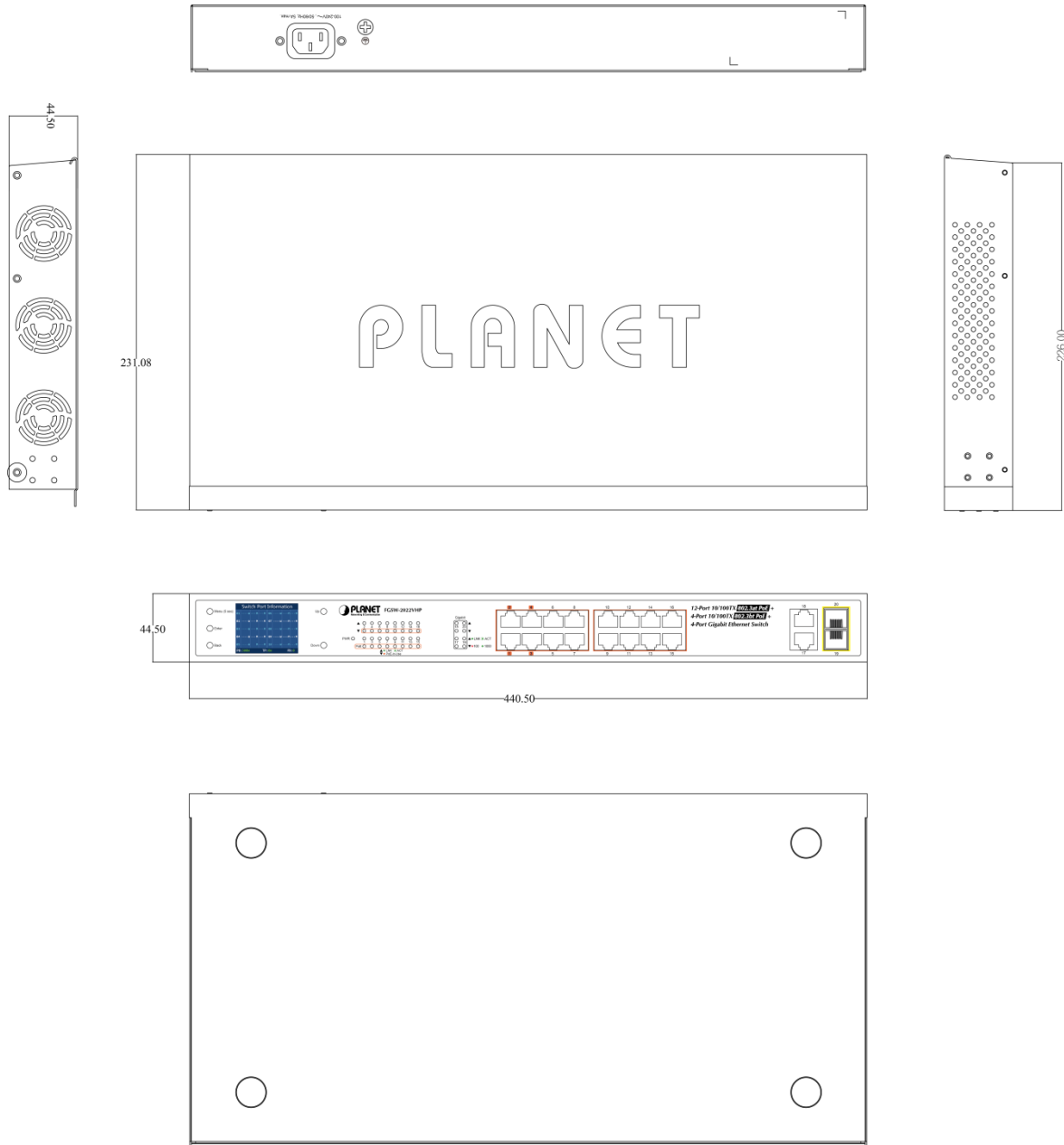

Unit: mm

■ **Front Panel**



■ Rear Panel



■ LED Definition

● System

LED	Color	Function
PWR	Green	Lights to indicate that the Switch has power.

● 10/100Mbps PoE Ports

LED	Color	Function	
LNK/ACT	Green	Lights	Indicates the link through that port is successfully established at 10/100Mbps.
		Blinks	Indicates that the Switch is actively sending or receiving data over that port.
PoE-in-Use	Amber	Lights	Indicates the port is providing DC in-line power.
		Off	Indicates the connected device is not a PoE powered device (PD).

● 10/100/1000Mbps TP or 1000Mbps SFP Slots

LED	Color	Function	
LNK/ACT	Green	Lights	Indicates the link through that port is successfully established at 1000Mbps.
		Blinks	Indicates that the Switch is actively sending or receiving data over that port.
100	Red	Lights	Indicates the port is successfully established at 100Mbps.
1000	Green	Lights	Indicates the port is successfully established at 1000Mbps.

3.4 Environmental Specifications

■ Operating

Temperature:	-10 ~ 60 degrees C
Relative Humidity:	10% ~ 90% (non condensing)

■ **Storage**

Temperature:	-15 ~ 70 degrees C
Relative Humidity:	5% ~ 90% (non condensing)

3.5 Electrical Specification

Input Voltage:	100~240V AC, 50/60Hz, 5A (max.)
Power Consumption (System on):	100V: 12.4 watts/42.3 BTU
	110V: 12.7 watts/43.3 BTU
	220V: 12.1 watts/41.2 BTU
	240V: 11.8 watts/40.2 BTU
Power Consumption (Data and PoE Full Loading):	100V: 347 watts/1184 BTU
	110V: 344 watts/1173.7 BTU
	220V: 332 watts/1132.8 BTU
	240V: 331 watts/1129.4 BTU

3.6 Regulatory Compliance

FCC Part 15 Class A, CE

3.7 Reliability

MTBF > 50,000hrs @ 25 degrees C

3.8 Basic Packaging

■ FGSW-2022VHP	x 1
■ User's Manual	x 1
■ Two Rack-mounting Brackets with Attachment Screws	x 1
■ Power Cord	x 1
■ Foot Pad	x 4
■ SFP Dust Cap	x 2

3.9 Packing Information

Box Dimensions (W x D x H):	315 x 493 x 72 mm
Box Weight:	4.4kg
Carton Dimensions (W x D x H):	509 x 238 x 345 mm
Carton Weight:	13.5kg
Quantity:	3pcs in one carton